

# PROCEEDINGS OF SPIE

[SPIDigitalLibrary.org/conference-proceedings-of-spie](https://spiedigitallibrary.org/conference-proceedings-of-spie)

## Photoresist microparabolas for beam steering

Rotich, Samuel, Smith, Jim, Evans, Alan, Brunnschweiler, Arthur

Samuel K. Rotich, Jim G. Smith, Alan G. R. Evans, Arthur Brunnschweiler, "Photoresist microparabolas for beam steering," Proc. SPIE 3287, Photodetectors: Materials and Devices III, (8 April 1998); doi: 10.1117/12.304502

**SPIE.**

Event: Optoelectronics and High-Power Lasers and Applications, 1998, San Jose, CA, United States

# Photoresist microparabolas for beam steering

S.K.Rotich, J.G.Smith, A.G.R.Evans and A.Brunnschweiler  
Dept. of Electronics and Computer Science,  
University of Southampton, Highfield, Southampton SO17 1BJ, UK.

## ABSTRACT

A simple grating mask has been used in an ordinary 5:1 projection stepper equipment to fabricate microscopic parabolic topographies in thick positive photoresist. The microparabolic surfaces created were coated with reflective material to form parabolic reflectors. Measurement values of focal length were in agreement with the expected theoretical values. The simple parabola forms the basis for the fabrication of compound parabolic reflector which can be used for beam steering. Normal incidence beam can be redirected by the compound parabolic reflector onto device areas in the vicinity of the focus.

**Keywords:** Photoresist profiles, Microparabolas, Micromirrors

## 1 INTRODUCTION

The use of complex surface topographies for a variety of optical elements in micro-optics has increased over the years[1, 2]. Though the existing micromachining technologies can produce a variety of curved microstructures, they are limited in some applications.

A more recent method of fabricating these microscopic curved structures is by patterning thick photoresist and either using the resulting shape as it is or replicating it into the underlying substrate using dry etching or ion beam milling techniques. Focus has been on the use of a grey-tone photomask with pixels which are too small to be resolved by the optical system[3, 4, 5].

This work reports a simple method for exposing photoresist through a grating mask into parabolic profiles, such as the one shown in figure 4(a), using an ordinary 5:1 stepper projection system. In this method the stepper equipment is used to project an out-of-focus image of the mask on the photoresist. This has an averaging effect on the transmission which results in smooth profiles.

The microstructures form the basis for the fabrication of compound parabolic micro-reflectors which are very suitable for such applications as thin solar cells.

## 2 EXPERIMENTAL PROCEDURE FOR PHOTORESIST EXPOSURE AND DEVELOPING

In the experiment 4-inch diameter silicon wafers were used. The wafers were cleaned in fuming nitric acid and subjected to a dehydration bake for 10mins in a 95°C convection oven. Thick positive photoresist (Shipley STR1075) was spun on silicon wafers to a required thickness of 9 $\mu$ m. This was for the fabrication of the simple parabolas. The photoresist was then softbaked for 40mins in a convection oven at 80°C and subsequently exposed through a half tone mask in the 5:1 stepper projection equipment. It was exposed for times ranging from 3.25s to 6.75s and developed for 1 minute. The exposed sections of the photoresist developed into cylinders with parabolic profiles of various depths depending on the time of exposure. The wafers were then rinsed in water, spin dried and coated with gold

In the stepper equipment used, the column that holds the projection optics is movable hence the system can be programmed to form an out-of-focus image at the focal plane. In particular it was programmed to expose photoresist whose top surface is at the normal focal plane or 10 $\mu$ m above it.

Exposure and development times are critical. Over-exposure results in the formation of vertical photoresist walls instead of curved ones. Under-exposure leaves a layer of photoresist on the substrate in areas which should be clear of photoresist. To obtain correct exposure time a calibration experiment was done. This involved exposing photoresist for a certain time and then measuring the depth of the photoresist developed. From the results of exposure depth versus time it is possible to estimate the required time to expose a given thickness of photoresist just to the silicon surface.

For the fabrication of the compound microparabolas a different reticle mask was used but designed using similar techniques as for the simple parabola. The mask was used to expose  $20\mu\text{m}$  thick photoresist for times ranging from 6.0s to 9.75s with equal increments of 0.25s. The wafers were then developed for 3 minutes, rinsed, spin dried and coated with gold.

### 3 THEORETICAL CONSIDERATION IN THE DESIGN OF THE MASK

Since the stepper is adjusted to project an out-of-focus image of the mask on the photoresist the diffraction effects are not significant as compared to the required blurring effect of the image. We can then treat the image formation as purely geometric. To a first approximation, for a given exposure time the depth of the photoresist removed during development is proportional to the intensity of light transmitted through the mask. A relative intensity pattern that would expose photoresist into a parabolic pattern with subsequent development into a parabolic profile is given by equation (1) and can be derived from the cartesian equation of a simple parabola whose vertex is at the origin.

$$I(x) = 1 - \frac{x^2}{4fy(x_{\max})} \quad (1)$$

where  $f$  is the focal length,  $x$  is measured parallel the photoresist surface and  $x_{\max}$  represents the maximum value of  $x$  for which  $y$  is the photoresist height. The simple parabola used in the design had a height of  $9\mu\text{m}$ , unit focal length and an  $x_{\max}$  value of  $6\mu\text{m}$ .

In designing the mask that would approximately yield the intensity pattern represented by equation (1) and illustrated in figure 1(a), the percentage transmission at any point along  $x$  was used to compute the relative sizes of opaque and clear slits that would yield the relevant transmission.

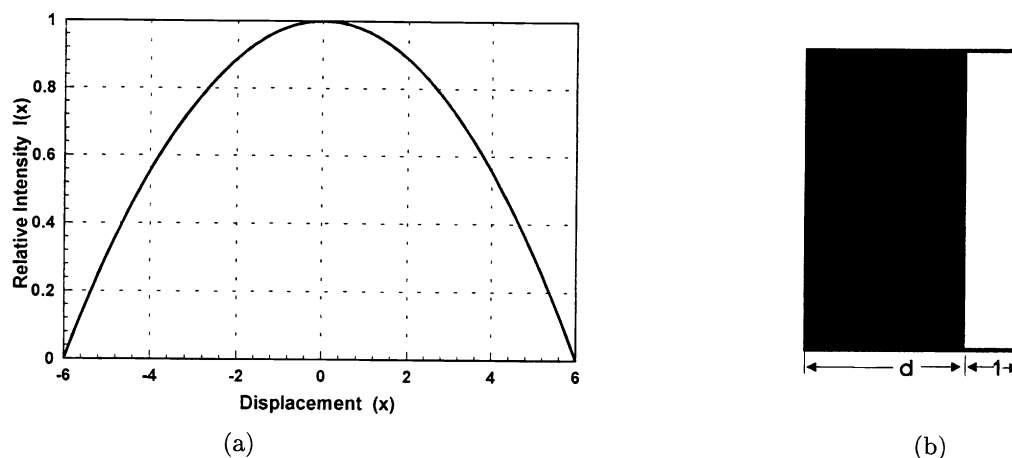

Figure 1: (a) Intensity profile approximation, (b) Dark and clear slit schematic for percentage transmission  $p$

On the mask the object dimensions are 5 times that of the image. Due to the e-beam writing machine restriction in which the minimum geometry that is possible is  $1\mu\text{m}$ , the width of the clear slit in the mask was kept constant at  $1\mu\text{m}$  while the opaque portion was varied. The schematic diagram of figure 1(b) shows the construction of the dark and clear slits for a percentage transmission  $p$  where  $p$  is  $100I(s)$  with  $s = 5x$ .

The width  $d(s)$ , of the opaque strip at a distance  $s$  from the centre of the parabola mask depends on the percentage transmission  $p(s)$  at that point and can be expressed as

$$d(s) = \frac{1 - p(s)}{p(s)} \quad (2)$$

The design of the grating involved linear addition of clear and corresponding opaque slits right from the 100% transmission centre to the 0% transmission sides. The size of the clear slit is maximum at the centre and decreases, according to the required percentage transmission, to zero at the sides of the mask. By using the stepper in out-of-focus mode the image is blurred and hence smoothing the intensity profile.

### 3.1 FABRICATION OF COMPOUND PARABOLAS

The simple parabola forms the basis for the fabrication of compound parabola. Figure 2, shows a schematic of a compound parabolic reflector constructed from two simple parabolas which have been shifted such that their focal points are  $6\mu\text{m}$  apart and are located under each other's curves. The thicker curvature sections represent the compound parabolic reflecting surface which steers a normal incidence beam onto an area near the focus underneath the adjacent mirror surface.

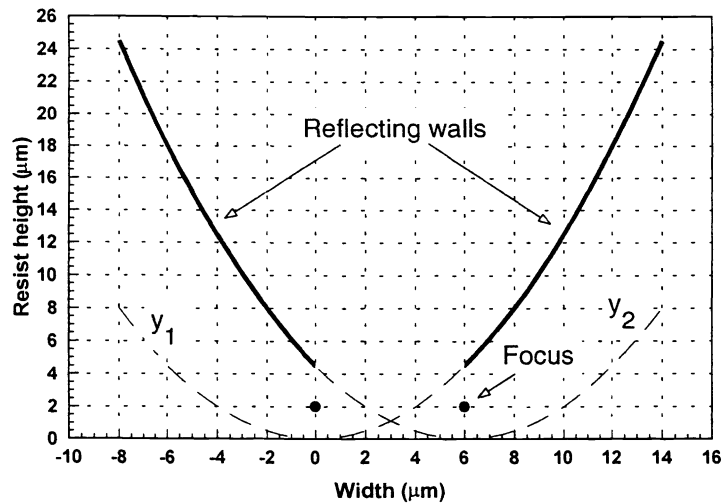

Figure 2: The compound parabolic deflector constructed from two parabolas

The design of the mask used for patterning  $20\mu\text{m}$  thick photoresist to give this profile was based on the values derived from the plot of  $d(s)$  against  $s$  in figure 3.

## 4 PRELIMINARY RESULTS

After developing the exposed photoresist and coating it with gold to minimize charging in the SEM, the wafer was cleaved across the grooves for SEM measurements.

Figure 4(a) shows an SEM photo of a parabola obtained by exposing the  $9\mu\text{m}$  thick photoresist for 3.25s using the grating mask while figure 4(b) shows a profile developed after exposing thick photoresist for the same duration but using a mask window of  $80\mu\text{m}$ . In the grating mask the design window is  $60\mu\text{m}$  (i.e on the mask the opening of parabola is  $5 \times 12\mu\text{m}$ ).

For the  $80\mu\text{m}$  window exposure the image profile contrasts well with that from the grating mask. The width of the image is about  $22\mu\text{m}$  and is far much larger than the expected value of  $16\mu\text{m}$ . For the design mask the width of the image is  $9\mu\text{m}$  against an expected width of  $9.5\mu\text{m}$  for a depth of  $5.7\mu\text{m}$ . It was observed that for any given exposure time the resulting image was a parabola whose dimensions were dependent on the time.

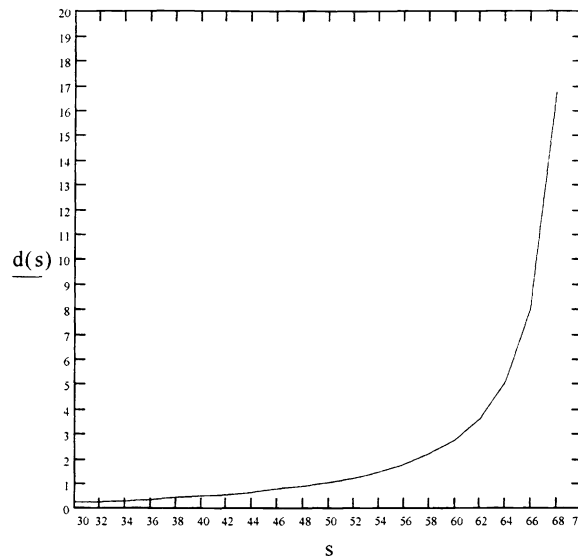

Figure 3: The opaque slit width  $d(s)$  at a distance  $s$  for the  $20\mu\text{m}$  thick resist case

Figure 5(a) shows an SEM photo of a cross-section of a microparabola obtained by exposing the  $9\mu\text{m}$  thick photoresist for 5.25s(just to the substrate) and in figure 5(b) a simple parabola plot has been superimposed on the photograph.

Vickers microscope type M41 Photoplan was used in the measurement of the focal length of the microparabolas. The diaphragm(D) for this microscope was used as an aid in the measurement, see figure 6. The diaphragm image(D') can be viewed when the reflected image(D'') of the diaphragm falls on the focal plane as illustrated in figure 6(b) and also in the photo scan (D') where the diaphragm image is in focus on resist surface

The stage position is further adjusted until a sharp bright line image(DL) appears in the middle of the parabola groove, see figure 6(c). This image is formed by the rays that are reflected once by the parabola before they come to a focus. The focus appears as a bright image line in the centre of the parabola groove as in photoscan DL

The rays that are reflected twice by the parabola walls form virtual images on either sides of the base of the parabola. The photoscan 2D and the schematic of figure 6(d) refer to this case.

To measure the depth of the parabola using the microscope, the stage position is adjusted (moved up) such that the diaphragm image(D) comes into focus when it is reflected by the base of the parabola as illustrated in figure 6(e)

Figure 7 shows a compound parabola developed in the  $20\mu\text{m}$  thick photoresist. When a compound parabola plot is superimposed on the profile as shown in figure 7 there is a good match on the upper part where there was a good percentage transmission approximation.

#### 4.1 DETERMINING THE FOCAL LENGTH

For the real image formed in the groove, as in figure 6(c), assume that the reflecting surface is part of a concave mirror. Hence applying the curved mirror equation, the focal length;  $f$ , can be computed. The object distance  $u$  and the image distance  $v$  can be determined from the stage positions.

$$\frac{1}{f} = \frac{1}{u} + \frac{1}{v} \quad (3)$$

From the readings of the stage positions, as tabulated in figure 1, the value of the focal length for the parabola made in the  $9\mu\text{m}$  thick photoresist was computed and found to be  $0.96\mu\text{m}$ . This is in agreement with the design value of  $1\mu\text{m}$ .

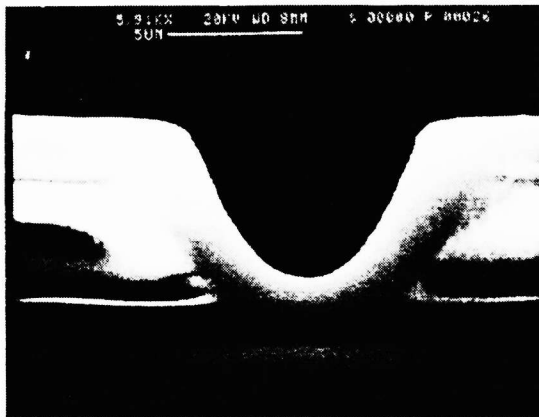

(a)

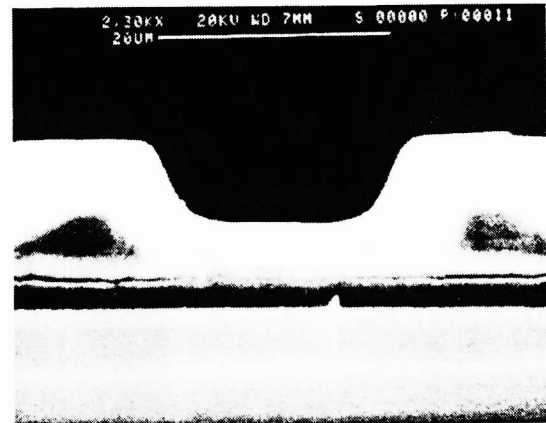

(b)

Figure 4: (a) Parabola developed after 3.25s exposure using grating mask. (b) Photoresist developed after 3.25s exposure using a  $80\mu\text{m}$  window

Table 1: Stage positions and corresponding knob reading

Stage position	reading( $\mu\text{m}$ )
Flat resist surface in focus (Focal plane reading)	21
Diaphragm image in focus on resist surface	27
Bright image line in groove	29
Sharp edge image of F.S.I in groove	36
Double bright line in the groove	33

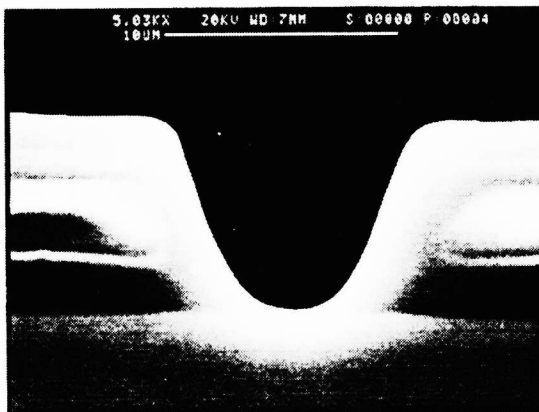

(a)

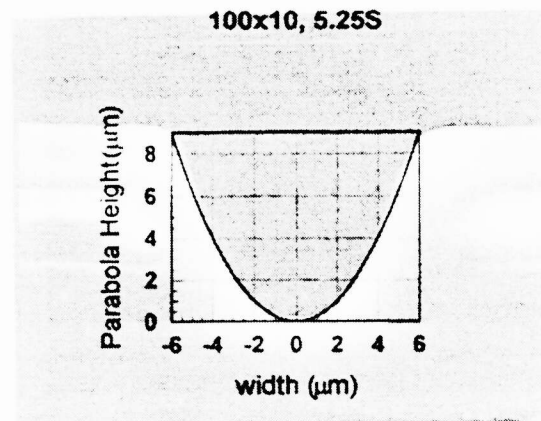

(b)

Figure 5: (a) Parabola developed after 5.25s exposure, (b) Parabola developed after 5.25s exposure with superimposed plot

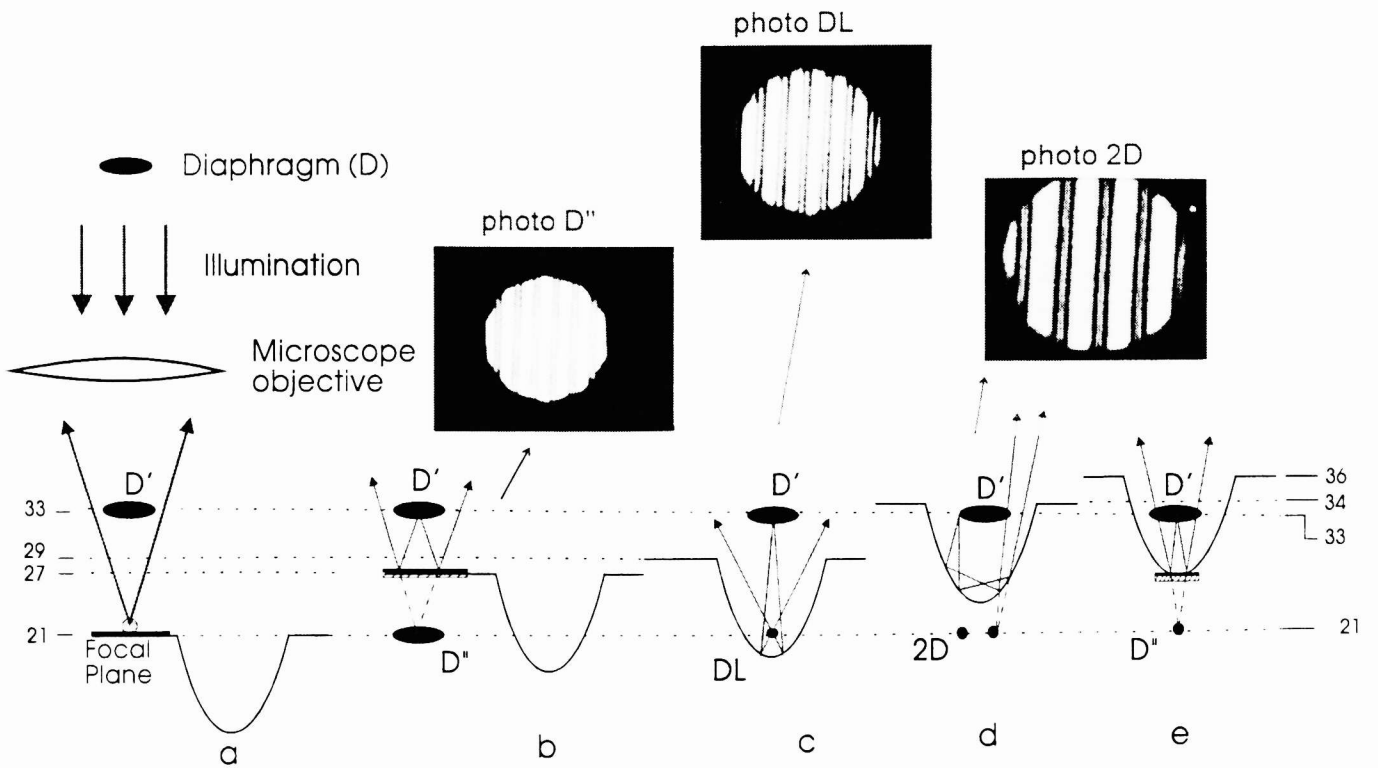
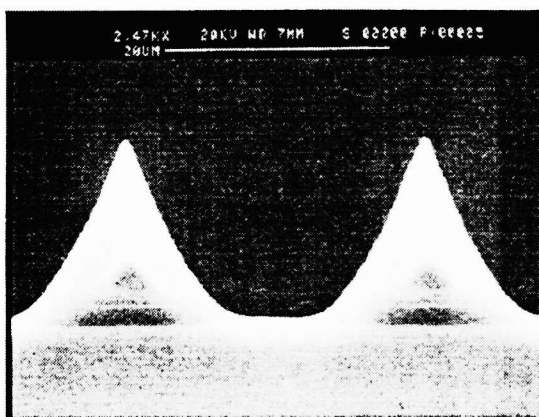
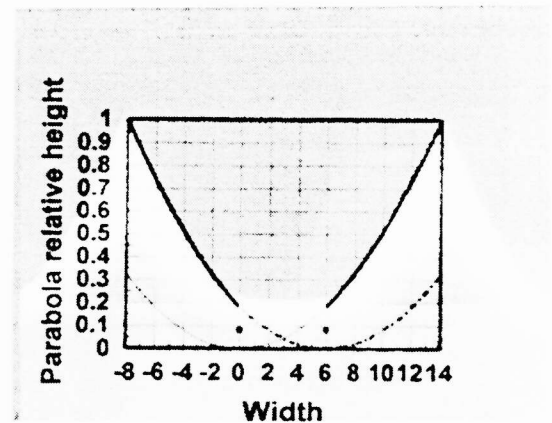

Figure 6: Schematic of microscope diaphragm image positions and associated photographs of the images.



(a)



(b)

Figure 7: (a) Compound parabola in  $20\mu\text{m}$  thick resist, (b) Fitting the compound parabola plot onto developed resist image

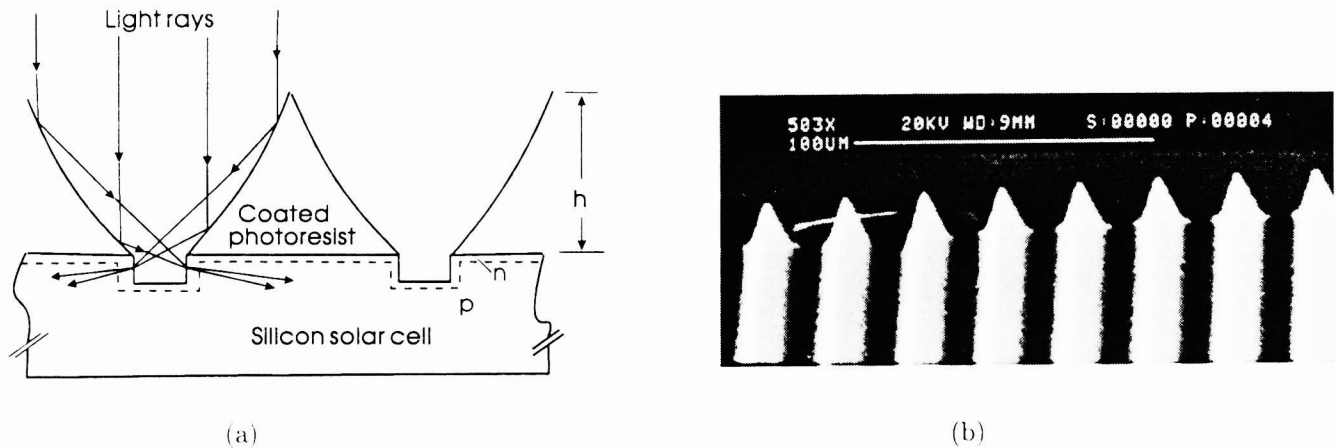

Figure 8: (a) Schematic cross-section of the compound parabolic deflector made from two overlapping simple parabolas showing the working principle. (b) Compound parabola arrays

## 5 CONCLUSION

A microfabricated simple parabola in  $9\mu\text{m}$  thick photoresist is presented. The measured focal length of the simple parabola is in agreement with the theoretical value. Using the 5:1 projection stepper in an out of focus mode produces smooth surfaces on the resist microstructures.

The simple parabola forms the basis for the fabrication of compound parabola whose surfaces can be coated to act as beam steering mirrors. Beam bending micro-optic components are useful in applications where active device areas are either (i) obscured by some other devices, or (ii) more efficient with oblique optical coupling. One application of these beam steering microstructures is in the thin solar cell. The compound parabolic reflector, as shown in figure 8(a) steers otherwise normal incidence light on the solar cell surface such that it is coupled into the cell travelling close to the surface. This means light can travel for long distances in the cell before it strikes the back reflector and hence the cell can be made very thin. The advantage of reducing the solar cell thickness is that photogeneration takes place closer to the p-n junction on the average, especially for the low energy photons, giving rise to a reduced bulk recombination and thus an increase in the current collected. A fabricated compound parabola is shown in figure 8(b) and work on the application is underway.

The process of fabricating photoresist microparabolas is compatible with the normal silicon processing procedures. If the microstructures are to be used as they are then they could be fabricated at the end of a device fabrication process. The microstructures pattern could be transferred onto other substrates using an ion beam milling where the mill rates for the substrate and the photoresist are carefully chosen so that there is maximum transfer of shape. Alternatively the microstructures can be used as masters for embossing purposes.

## ACKNOWLEDGEMENT

We wish to thank all the technical staff of Microelectronics Centre, Department of Electronics and Computer Science, Southampton University, who worked on the project. Special thanks go to Mrs. J. Clarke for her contribution in mask preparation and N. Clayton for his photolithography work.



## REFERENCES

- [1] B. Wagner, H.J.Quenzer, W.Henke, W.Hoppe and W. Pilz, "Microfabrication of complex surface topographies using gray-tone lithography", *Sensors and Actuators A* 46-47, Elsevier Science, 1995, pp89-94.
- [2] D.R.Purdy, "Fabrication of complex micro-optic components using photo-sculpting through half-tone transmission masks", *Pure and Applied Optics* (IOP) 1994, pp167-175.
- [3] A. B. Frazier, C. H. Ahn, and M. G. Allen, Development of micromachined devices using polyimide-based processes, *Sensors and actuators A* 45, Elsevier science, 1995, pp47-55.
- [4] G. Gal, B. Herman, W. Anderson, D. Shough, D.R.Purdy and A. Berwick, "Development of the dispersive Microlens", *Pure and Applied Optics* (IOP) 1994, pp97-101.
- [5] M. Abitbol and N. Eisenberg, "A new process for Manufacturing Arrays of Microlenses on Various Substrates", *SPIE* vol.1344 1990, pp110-121.